

Footswitches

Tough, Durable Mini-Mats for Specialty Applications

Larco's standard safety mats provide durable and reliable presence-sensing for the most demanding industrial safety applications. Larco footswitches are no different...these miniature Larco safety mats work consistently in the toughest, most demanding industrial environments. Available in the standard configuration described below and in custom models to fit your exact needs, Larco footswitches can provide a dependable solution to any need.

Standard Footswitches

Details & Specifications

- Normally-open momentary contact switch
- High-durability steel electrode construction
- Proprietary molded vinyl shell
- Designed to meet IP67 and NEMA 6
- Water-tight and totally submersible
- Ribbed to prevent slipping
- Variety of colors
- Temperature range -35°F-120°F (-37°C-49°C)
- Activates with 3-5 lbs. of foot pressure
- Excellent chemical resistance. For a complete chart, contact Larco.

Dimensional Diagrams

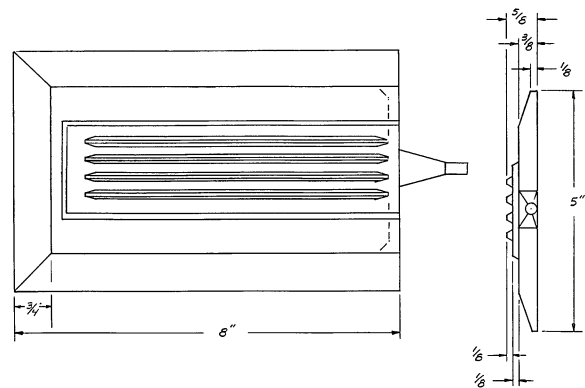

Larco Standard Footswitch (P/N 212419)
Contact Larco for pricing.

**For more information on Larco safety products and custom footswitches, visit
www.larcomfg.com**

1902 13th Street S.E. • PO Box 547 • Brainerd, MN 56401
phone 218-829-9797 • toll free phone 800-523-6996 • fax 218-829-0139 • toll free fax 800-589-3705

www.larcomfg.com

IS-TB15-November 2003