

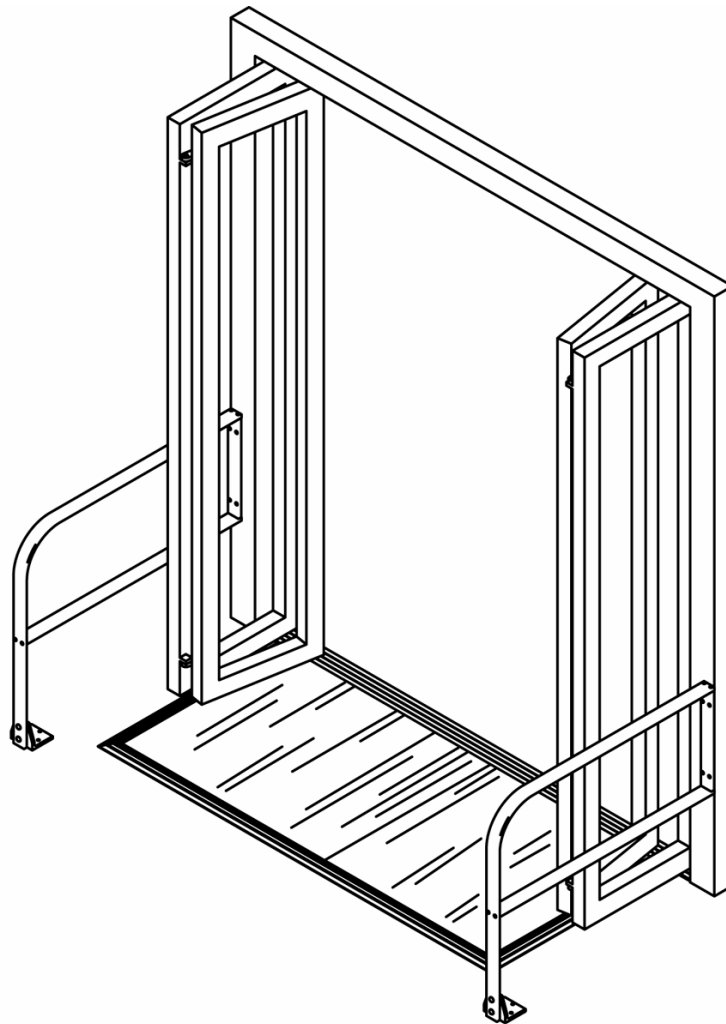

Architectural Specifications

Presence-Sensing Door Control Packages BF03-60 through BF03-96
for Bi-Fold Automatic Doors
with Mats on One Side and One Way Traffic



The Activation and Safety System Packages discussed here are designed to comply with The American National Standard for Power Operated Pedestrian Doors in ANSI A156.10. Each package includes presence-sensing activation and/or safety mats, ramp edge trim kits, threshold trim and guide rails intended for bi-fold automatic doors.

1 GENERAL

1.01 WORK INCLUDES

A. Installation of Presence-Sensing Activation Mat Systems to initiate and control the safe opening of bi-fold automatic doors.

1. Installation of aluminum ramp edging.
2. Installation of aluminum threshold.

B. Installation of Presence-Sensing Safety Mat Systems to prevent opening or closing, as appropriate, for bi-fold automatic doors.

1. Installation of aluminum ramp edging.
2. Installation of aluminum threshold.
3. Installation of aluminum double line guide rails.

1.02 RELATED SECTIONS

EDIT TO SUIT PROJECT REQUIREMENTS

- A. 08400 – Entrances and Storefronts
- B. 08460 – Automatic Entrance Doors
- C. 08470 – Revolving Entrance Doors
- D. 08720 – Automatic Door Operators
- E. 08710 – Door Hardware

1.03 REFERENCES

A. 28 CFR Part 36 Nondiscrimination on the basis of Disability Accommodations and Commercial Facilities.

B. ANSI 156.10 American National Standard for Power Operated Pedestrian Doors.

C. International Standards Organization (ISO) 9002

1.04 SUBMITTALS

A. Product Data: Manufacturer's installation instructions for presence-sensing activation and safety mat systems, including perimeter ramp edging and threshold trim.

B. Layout Drawings: Presence-sensing mat system layout drawings are unique to each installation and are available upon request once the door type, clear opening and anticipated traffic pattern have been established.

1.05 QUALITY ASSURANCE

A. Installer: Acceptable to presence-sensing mat manufacturer with certified evidence of suitable training for the installation of presence-sensing activation and safety mat systems including ramp edges, thresholds and guide rails similar to those specified herein.

PART 2 – PRODUCTS

2.01 BASIS OF DESIGN

A. Specification Basis: Provide products specified herein produced by Larco, an Acrometal Company, 1902 13th Street SE, Brainerd, MN 56401. Tel: 800-523-6996; Fax: 800-589-3705; http: www.larcomfg.com

SELECT ONE SUBSTITUTION PARAGRAPH

B. No Substitution

B. Architect approved Substitution

B. Architect approved Substitution will be limited to the following:

2.02 BI-FOLDING DOOR ACTIVATING DEVICES

Presence-sensing mats specified herein are of molded vinyl, steel plate electrode, normally open switch mats. High-grade steel plates form the electrode contacts, which are separated by insulating spacers. The steel electrode is encapsulated in unique vinyl. All elements, including the cord connection to the electrode, are watertight after heat curing. Molded presence-sensing mats are impervious to all forms weather and most industrial cleaners. This superior design affords maximum sensitivity, great durability and ease of use.

All Devices are compliant with ANSI/BHMA A156.10

Presence-sensing mats are compatible with all automatic doors. Colors can be coordinated to match the building façade or store front. Greetings, informational messages and corporate logos can be combined for complete entrance tie-in.

Presence-sensing mat systems eliminate confusion in the general population, particularly with the very young and the elderly. Clearly defined sensing areas for activation allow the pedestrian to anticipate the door's actions (opening or closing) with confidence. This aspect is especially critical in nursing homes and hospitals where patients, residents and staff find the predictability of presence-sensing mats easy to understand and use. Presence-sensing mats are ideal for swinging, folding, sliding and revolving doors with none of the limitations and required adjustments associated with electronic sensors.

A. Technical Data/Specifications

Operating temperature range is -35°f to 120°f.

Estimated MTBF of 10,000,000 operations.

Intermittent loads up to 3000 PSI

Dielectric strength - 300 volts/mil

Shore "A" hardness 72 +/-2

MTBF = Mean Time Between Failures

Mounting is accomplished using aluminum ramp edging and mechanical fasteners. Trim kits are installation ready and include miters, drilling, countersinking, and stainless steel screws with anchors.

- 1.) Mounting trim can be color matched to the building façade.

B. Select Finish

- 1.) Presence-sensing mats are standard in black, brown or gray. Yellow, red, blue and cordovan are also available.
- 2.) Aluminum extrusions used to secure mat systems in place and serve as ramp edging and threshold cover, are standard in mill finish. Anodized colors to match storefront also available. Contact the factory for this option.
- 3.) Standard guide rails utilize 1/2 inch x 1-1/2 inch aluminum extrusion with a minimum height of 30 inches. Lengths are specific to each door package and are fully ANSI A156.10 compliant.

2.03 BI-FOLDING DOOR SAFETY DEVICES

Presence-sensing mats specified herein are of molded vinyl, steel plate electrode, normally open switch mats. High-grade steel plates form the electrode contacts, which are separated by insulating spacers. This steel electrode is encapsulated in vinyl. All elements, including the cord connection to the electrode, are watertight after oven curing. Molded presence-sensing mats are impervious to all forms weather and most industrial cleaners. Manufactured by Larco, this superior design affords maximum sensitivity, great durability, and well defined detection zones.

Presences-sensing mat systems eliminate confusion in the general population, particularly with the very young and the elderly. Clearly-defined sensing areas for activation allow the pedestrian to anticipate the door's actions (opening or closing) with confidence. This aspect is especially critical in nursing homes and hospitals where patients, residents and staff find the predictability of presence-sensing mats easy to understand and use. Presence-sensing mats are ideal for swinging, folding, sliding, and revolving doors with none of the limitations and required adjustments associated with electronic sensors.

A. Technical Data/Specifications

Operating temperature range is -35°f to 120°f.
MTBF of 10,000,000 operations (Estimated).
Intermittent loads up to 3000 PSI
Dielectric strength - 300 volts/mil
Shore "A" hardness 72 +/-2

MTBF = Mean Time Between Failures

Mounting is accomplished using aluminum ramp edging and mechanical fasteners or the Larco Labor Saver system. Trim kits are installation-ready and include miters, drilling, countersinking, and stainless steel screws with anchors where applicable.

- 1.) Mounting trim can be color matched to the building requirements.

2.04 BI-FOLDING DOOR ACTIVATION AND SAFETY SYSTEM PACKAGE

SELECTING THE PACKAGE TO SUIT THE PROJECT

Presence-sensing mat system packages, as manufactured by Larco, have been conveniently assembled into easy-to-order units. Each package is designed to meet current ANSI/BHMA A156.10 standards for activation and safety. Individual door packages are intended to provide all the necessary materials to make a bi-folding automatic door, regardless of size or traffic pattern,

safe to operate. Larco’s Bi-Folding Door Packages include presence sensing mats for activation and/or safety, aluminum trim sets for all mats, aluminum threshold, and a pair of aluminum guide rails matched to each package based on the “clear opening” of the door and the anticipated traffic pattern. All materials, including mounting hardware, are included under a single package part number.

The following presence-sensing mat systems meets or exceed ANSI/BHMA A156.10 standards for power operated pedestrian doors providing complete activation and safety zones for a bi-folding automatic door.

Bi-Fold Door Package Selection: In order to select the correct package for your installation, answer the following questions.

- 1.) What is the largest folding panel size? (FX Panel).
- 2.) What is the intended traffic pattern? (One way or two way).

A. Select the package description that best suits the project

Door Project Description	Package Number	Panels Up To
Bi-Fold Automatic Doors, Mats on the Safety (Fold) Side of the Door One Way Traffic is Intended	BF03-60	Up to 62”
	BF03-72	Up to 74”
	BF03-84	Up to 86”
	BF03-96	Up to 96”

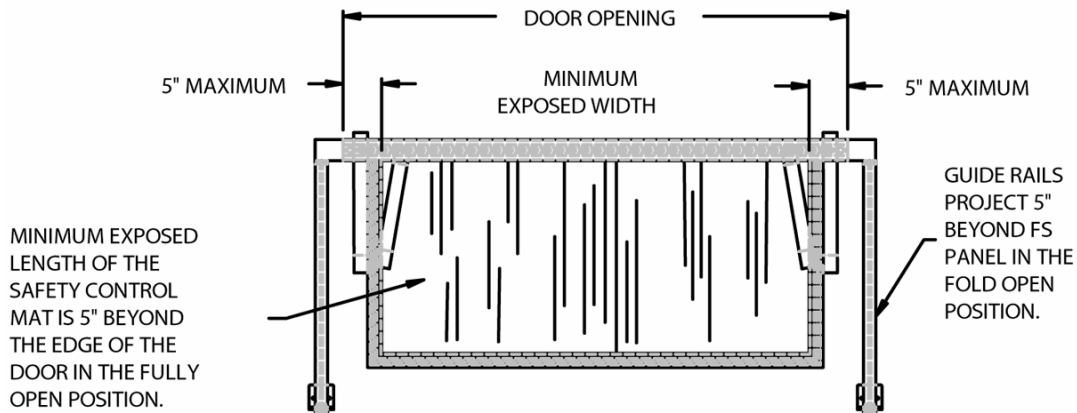

Detailed CAD drawings in digital format are available upon request.

PART 3 – EXECUTION

3.01 EXAMINATION

A. Verify the following:

1. Installation dimensions are acceptable for the installation.
- 2 Floor conditions are suitable for activation and safety presence-sensing mat performance.

B. Do not proceed unless or until unsatisfactory conditions, which are detrimental to a proper and timely completion of the installation, have been corrected.

3.02 INSTALLATION

- A. Pursuant to the OEM door manufacturer's published instructions and approved installation drawings.
- B. Compliance with Larco installation instructions.

3.03 ADJUSTING

- A. Test completed installation pursuant to published instructions for presence-sensing activation and safety system package.
- B. No adjustments are necessary.